

**Plan View Elevation - Roadside Range Type F**

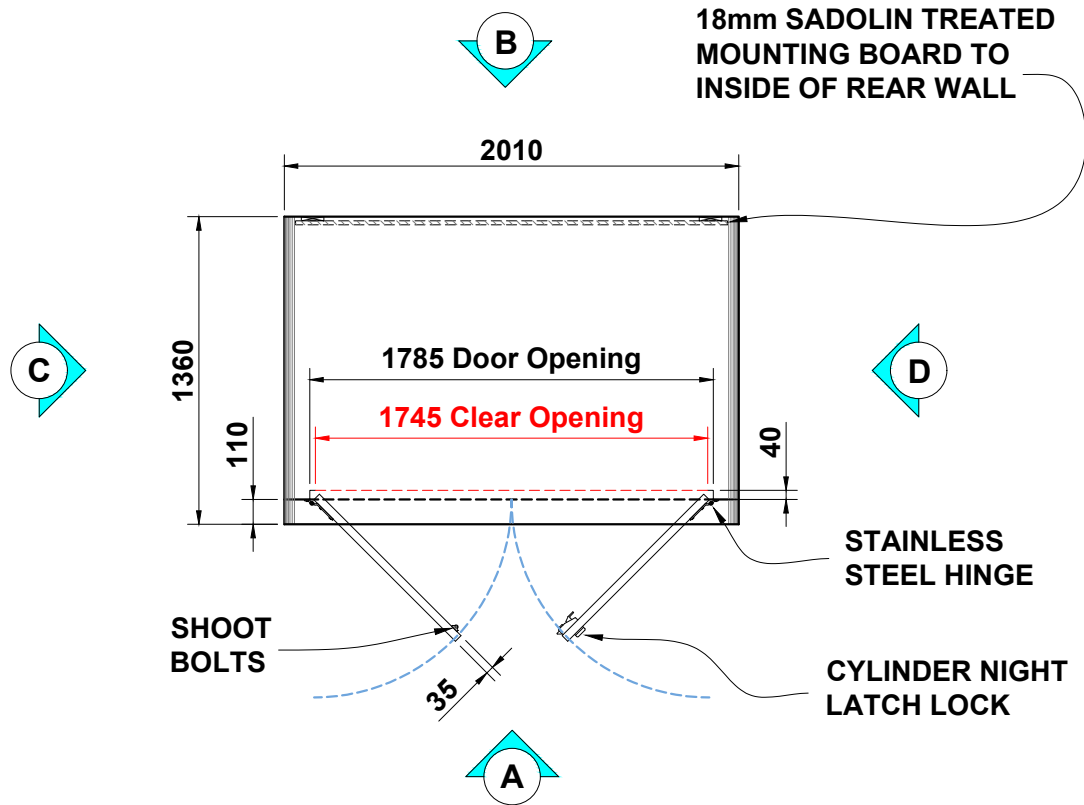

**Elevation (A) (front)**

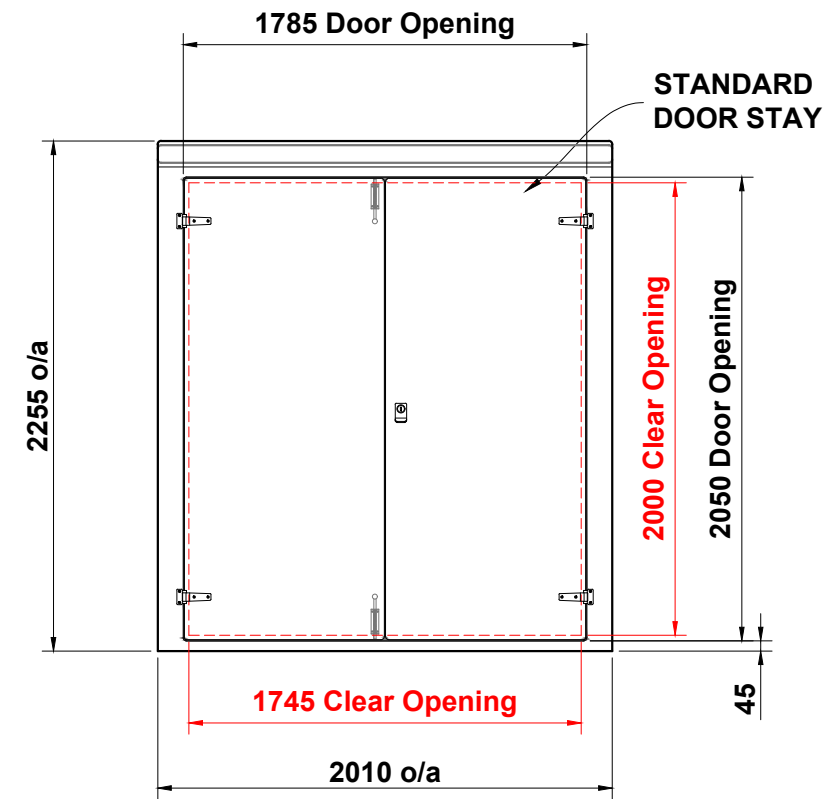

**Elevation (B) (rear)**

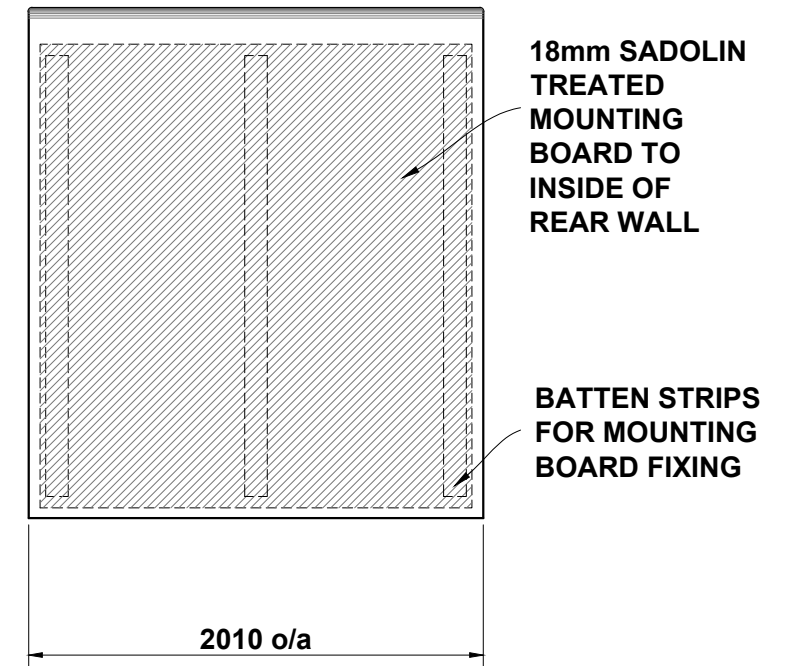

**Elevation (C) (l/h side)**

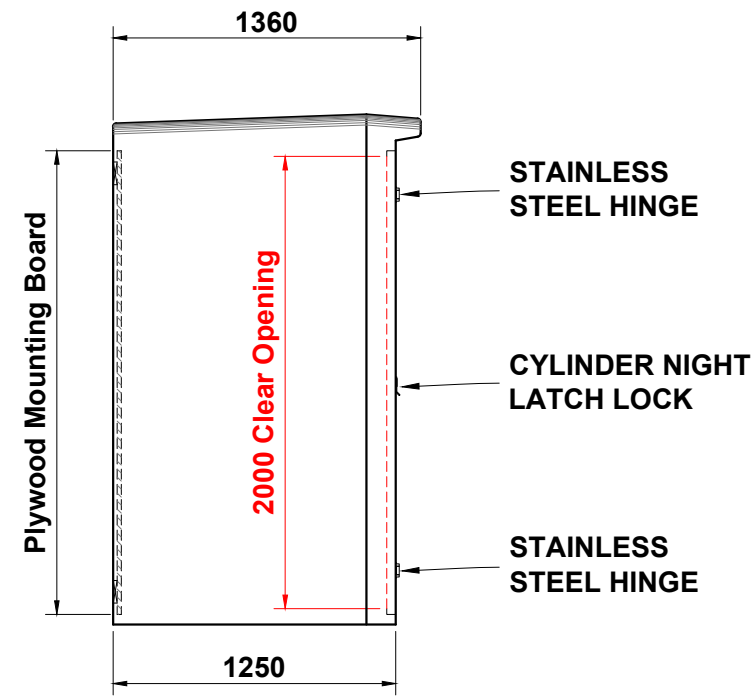

**Elevation (D) (r/h side)**

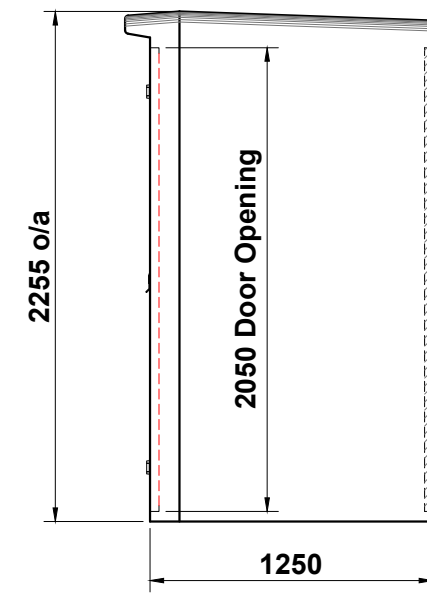

**Elevation (C) (l/h side) Door Open**

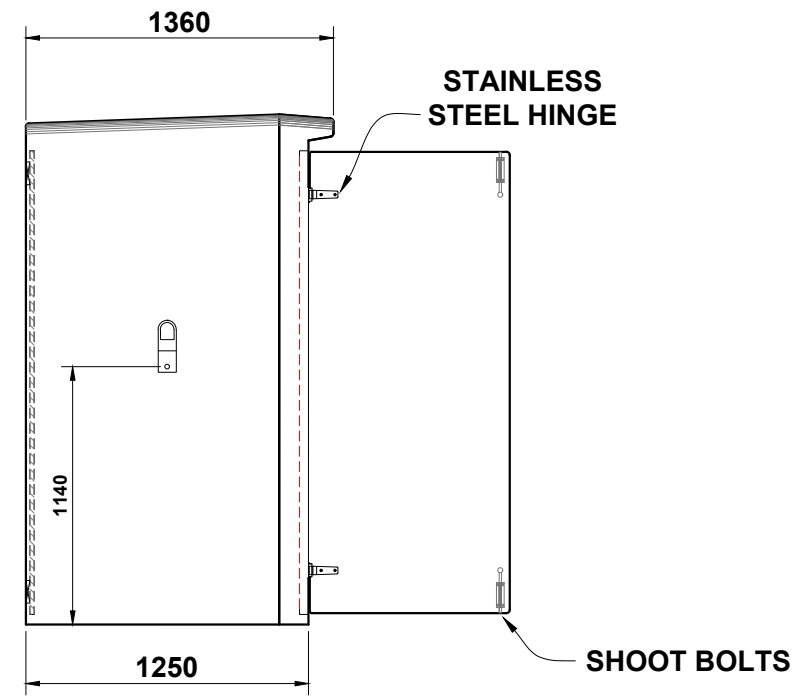

**Elevation (D) (r/h side) Door Open**

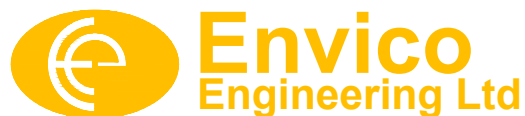
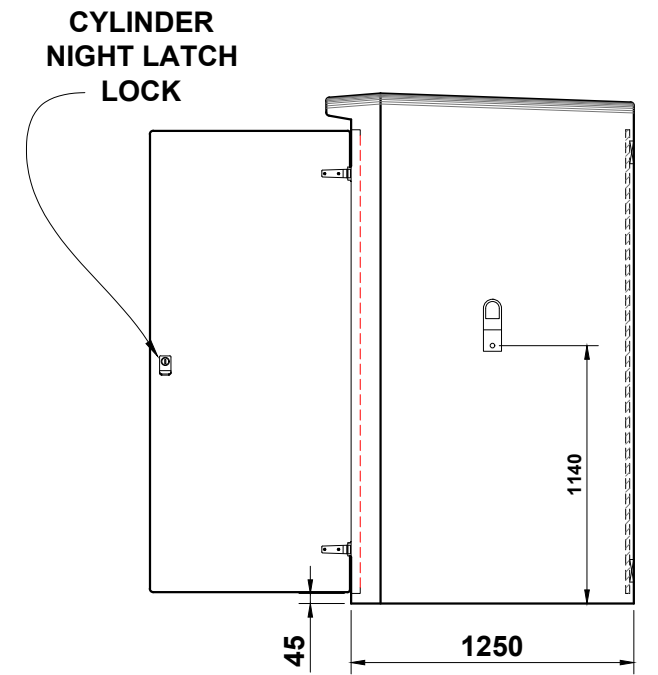

THE DRAWING AND DESIGN IS THE PROPERTY OF ENVICO ENGINEERING LTD. AND WITHOUT THE WRITTEN CONSENT OF ENVICO ENGINEERING LTD. MAY NOT BE COPIED IN WHOLE OR IN PART OR COMMUNICATED TO A THIRD PARTY OR USED FOR ANY PURPOSE.

**Envico Engineering Limited**

Tel : 01792 794 619  
Fax : 01792 793 532

Nantylfin Road (South), Enterprise park, Llansamlet  
Swansea, SA7 9RG, South Wales.

INTERNAL WIDTH : 1980mm

INTERNAL DEPTH : 1180mm

INTERNAL HEIGHT : 2215mm

APPROX. WEIGHT : 400kg

Date : 14/16/2019

Drawn By : D O'Malley

GRP HOUSING : ROADSIDE RANGE TYPE F

Drawing Scale : Not To Scale

Drawing No : TYPE F

Rev :